

# AM8e T1 Adapter

## Model 300071

(used with Model AM8 PCM/VF call analyzer)

### Instruction Manual

Revision D

April 11, 1997

Technical Data Subject to  
Change without Notice

**Ameritec**  
**CORPORATION**

---

---

760 Arrow Grand Circle  
Covina, CA 91722 USA  
TEL (818) 915-5441  
FAX (818) 915-7181

We made our name with  
American Technology

ISO 9001 Registered Company

of this  
art

## Record of Revisions

September 16, 1993	Original Release for 300068 units
January 4, 1994	Add information on the Model 30071 unit which provides for conversion between A-law and $\mu$ -law Speech Encoding. Shaded text identifies descriptions that apply only to the Model 300071.
July 7, 1994	Model 300068 discontinued. Manual is for Model 300071 only which retains all features of Model 300068. Shading and references to two models removed. Corrected Figure 2. Other corrections as needed.
April 11, 1997	Corrected part number on title page to read 18-0053. Updated document format.

This manual was produced on a Power Macintosh using MS Word 6.0 and Canvas 3.0. Graphics were printed in EPSF format.

<b>SECTION</b> .....	<b>1-1</b>
PCM/VF Call Analyzer.....	1-2
T1 Adapter.....	1-3
Protocol Table Development Guide and Disk .....	1-4
Flow of T1 Test Configuration.....	1-4
<b>FUNCTIONS OF THE T1 ADAPTER</b> .....	<b>2-1</b>
Panel Controls and Indicators.....	2-1
VR ON OFF:.....	2-1
FLAMING switch and indicators.....	2-2
PRO SUPPRESS switch and indicators.....	2-2
PCM1 and PCM2 indicators .....	2-3
PCM1 and PCM2 HISTORY indicators .....	2-3
HISTORY RESET switch.....	2-4
MODE CONVersion T1 → E1 switch and indicators.....	2-4
Connection to the AM8e Call Analyzer .....	2-5
Connection to AM8e LINE/TIMS — AM8e Interface Connection.....	2-5
Connections to Test Leads .....	2-6
Setting the Operating Conditions .....	2-6
Remote Control of T1 Adapter .....	2-9
Remote Setup ((ADP=xyz) command) .....	2-9
Remote Status ((RADP) command): .....	2-10
<b>TECHNICAL SPECIFICATIONS</b> .....	<b>3-1</b>
Interface .....	3-1
(PCM1 and/or PCM2).....	3-1
PCM1 and PCM2 Transmission Error Indicators.....	3-2
PCM1 and/or PCM2.....	3-3
1 General.....	3-3
<b>1 Tables</b>	
Model 30-0071 AM8e T1 Adapter Front Panel .....	2-1
Signal Connections .....	2-5

## Index

- .....1-1,2-9>2-10,3-1
- .....1-1>1-3,3-1
- .....1-1,2-8
- .....1-1,1-4
- .....1-2>1-3
- .....1-1,1-3,2-1
- .....2-5,2-7
- .....2-4,2-9>2-10,3-1
- rs.....2-4
- nmand.....2-9
- n.....2-3,3-2
- pattern.....2-2
- rsion.....2-3
- lyzer.....1-1
- .....2-2,2-9>2-10,3-1
- .....2-8
- .....1-1>1-2
- .....2-2,2-9>2-10,3-1
- Zero Suppression.....2-2
- ns.....2-3,3-1
- .....2-3,2-10,3-1
- .....2-5
- .....2-8,3-1
- .....1-1>1-3,2-7>2-8,2-10
- .....2-6,2-8
- 0.....1-3,2-6,2-8
- ffice).....2-5>2-7
- .....2-1,2-4,2-9>2-10
- .....2-9>2-10
- .....2-5>2-6
- .....1-4,2-5>2-8
- Y" bits.....2-2
- .....2-2>2-7,2-10
- ols.....1-2,1-4
- .....2-2,2-9,3-1
- .....1-3
- Disk.....1-4
- .....1-4
- .....1-2>1-3,2-8,3-1
- .....2-2,2-7,2-9>2-10
- andard.....2-7
- r Frame.....2-2
- .....2-8
- Frame Error.....2-3, 2-10,3-1
- Frame Synce.....2-3,2-7,2-10,3-1
- framing.....2-2>2-3, 2-7>2-9,3-1
- front cover.....1-3
- front panel.....1-3>1-4,2-1,2-7>2-9
- ground.....2-5
- History Reset.....2-4,2-9>2-10
- History Status.....2-4,2-10
- Imitate.....2-8
- input.....1-3,2-8
- Input.....2-8
- Instruction.....1-1
- interface.....1-2
- interfaces.....1-3,2-6
- Internal Clock.....2-8
- jack.....2-5>2-7
- jacks.....1-4,2-5>2-7
- LED.....2-2>2-3,2-7,2-9>2-10
- Lid.....1-3
- Line/Tims.....1-3,2-5,2-7
- local standards.....1-2
- Master clock.....2-8
- Mbps.....1-2>1-4,3-1
- monitor.....1-3,1-4,2-8,3-1
- MS/Dos.....1-2,1-4
- Note.....1-2>1-4,2-1>2-2,2-5>2-8
- On/Off Switch.....2-1
- output.....1-3
- overflow.....2-3
- panel.....1-2>1-3,2-2,2-5>2-6,2-9
- PC.....1-2
- PCM.....1-1>1-2,2-3>2-6,2-8,3-1
- PCM1.....1-3>1-4,2-3>2-8,2-10,3-1
- PCM2.....1-3>1-4,2-3>2-8,2-10,3-1
- pcm int clk.....2-8
- pcm loop clk.....2-8
- power.....1-3,2-1,2-5,3-1
- Protocol.....1-1>1-4,2-3,2-8,3-1
- Protocol Table Development Guide.....1-1>1-4
- RADP.....2-10
- RAI (Yel) Alm.....2-3,2-10
- rear panel.....1-3>1-4,2-5,2-7
- Red alarm condition.....2-3,3-1
- Remote Status.....2-10
- RS232.....2-9
- Rx.....1-2>1-3,2-6>2-7
- signal.....2-7
- signaling.....1-2>1-3,2-2,2-7
- signaling bits.....2-2,2-7
- Slip.....2-3,2-10,3-1
- span.....2-2
- spans.....1-2>1-3,2-3
- status message.....2-9
- switch.....2-1>2-2,2-4
- switches.....2-9>2-10
- synchronized.....2-3
- T1 —> E1.....(see Code Conv)
- T1 spans.....1-2>1-3,2-3
- Technical specifications.....3-1
- test.....1-2,1-4,2-7>2-8
- test set.....1-2
- To AM8e Line/TIMS.....1-3,2-5,2-7
- Tx.....1-2>1-3,2-6>2-7
- underflow.....2-3
- Yellow alarm.....2-3,3-1
- ZCS.....2-2,2-9>2-10,3-1
- Zero Code Suppression.....2-2
- Zero Suppress.....2-2,2-7,2-9>2-10
- zero suppression.....2-2,2-9>2-10,3-1
- zeroes.....2-2>2-3,2-7

## INTRODUCTION

This manual is intended for use with the Ameritec AM8e T1 Adapter (P/N 30-0071). This manual should be used in conjunction with the AM8e PCM/VF Call Analyzer Instruction Manual (P/N 18-0035), and the AM8e Protocol Table Development Guide (P/N 18-0040).

This manual is divided into two major sub-sections, as listed in the Table of Contents. Section 1 ("1. INTRODUCTION") provides an overview of the AM8e VF Call Analyzer, the AM8e T1 Adapter and Protocol Table Development Guide; all of which are of equal importance to the instructions in this manual.

Section 2 ("2. OPERATION OF THE T1 ADAPTER") describes the Model 30-0071 T1 Adapter, its front panel, connections, setting up operating conditions and commands.

A Table of Contents and an Index to subjects are at the beginning of this manual.

## PCM/VF Call Analyzer

Ameritec AM8e PCM/VF Call Analyzer is a test set that is designed to emulate, monitor and analyze signaling activity at the PCM interface point on an established connection.

For brevity, the AM8e PCM/VF Call Analyzer will be referred to as the "AM8e analyzer" in the remainder of the text.

AM8e Call Analyzer can emulate or monitor and identify activities at the near end or far end (Rx) of either of two 2.048 Mbps PCM spans. This unit is described in the "AM8e PCM/VF Call Analyzer Instruction Manual" (P/N 18-0035).

Testing can be performed on any of 30 voice channels on the spans, and the AM8e Call Analyzer may operate with any selection of one of eight signaling protocols stored in the unit.

Eight protocols may be loaded into the AM8e Call Analyzer, either from the factory or by the user with an MS/DOS Compatible PC. The user may develop custom protocols to conform to local standards, as described in the "AM8e Protocol Table Development Manual".

Although the AM8e Call Analyzer can test 2.048 Mbps E1 spans, it is not specifically designed for direct connection to 1.544 Mbps T1 spans; therefore, Ameritec has developed the T1 Adapter.

## 1 Adapter

Model 30-0071 AM8e T1 Adapter is designed to replace the front cover (or "Lid") of the AM8e Call Analyzer. The illustration on the cover of this manual shows both units as they should be set up for use.

For brevity, the Model 30-0071 AM8e T1 Adapter will be referred to as the "T1

Adapter". The T1 Adapter is electrically connected to the AM8e Call Analyzer via a ribbon cable "TO AM8e LINE/TIMS" connector on its front panel to the LINE/TIMS connector on the rear panel of the AM8e Call Analyzer. All power, PCM1, PCM2 input and output connections between the T1 Adapter and the AM8e Call Analyzer are via this ribbon cable.

1.544 Mbps T1 spans are via bantam jacks on the front panel of the T1 Adapter.

Typically, the T1 Adapter converts (or "maps") the 24 signaling and data channels of a 1.544 Mbps T1 span (PCM1 and PCM2) to the first 24 signaling and data channels of a 48 Mbps PCM1 and PCM2 Rx and Tx interfaces on the AM8e Call Analyzer. It also provides conversion between A-law and  $\mu$ -law speech encoding.

**Channels 25 through 30 are not accessible and are used for control communication between the T1 Adapter and the AM8e Call Analyzer.**

## Protocol Table Development Guide and Disk

AM8e Protocol Table Development Guide (P/N 18-0040) is a user's guide to writing custom signaling protocols for the AM8e on an MS/DOS-compatible Personal Computer. Also included with the Guide is a Development Disk which must be used together with third-party software as described in the Guide. Custom protocols are used to monitor and emulate 1.544 Mbps spans via the T1 Adapter.

In TABLE A-2 of the AM8e Protocol Table Development Guide: Action Data AC\_ADAPTER Action Code is amended to include "2 = T1 Adapter" in order to use the 30-0071 T1 Adapter.

In many cases, Ameritec has developed protocols which may be supplied on a disk (or used with the AM8e Call Analyzer). Protocols are listed in an Addendum to the Guide (P/N 18-0126). For more information contact your local Ameritec Sales or Marketing Group representative.

## View of T1 Test Configuration

When a T1 circuit, the Switch or Terminal under test is connected to the PCM1 and/or PCM2 jacks on the front panel of the T1 Adapter. Line connections are described in detail in sub-section 2.3.



# ATION OF THE T1 ADAPTER

## nt Panel Controls and Indicators

e 1 shows the front panel of the T1 adapter. The following sub-sections  
ibe the controls and indicators.

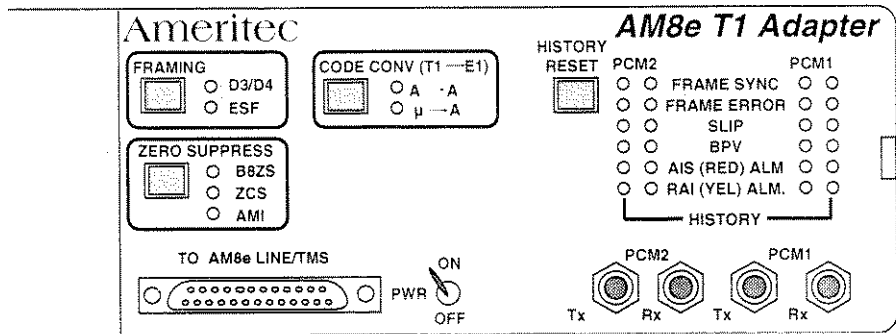

Figure 2-1. Model 30-0071 AM8e T1 Adapter Front Panel

### Power ON/OFF — Power ON/OFF Switch:

This switch allows you to turn the power on and off.

Power (+16V) is provided by the AM8e Call Analyzer which must also be turned ON. The cable between the AM8e Call Analyzer and the T1 Adapter must also have been connected (Refer to 2.2.1).

## AMING switch and indicators — Span Framing Type Selector

The framing switch allows you to select the span framing type:

**D3** Uses 12 separate frames in a super-frame. The signaling bits are identified as "a" and "b"; "c" and "d" bits are not used.

Extended Super Frame uses 24 frames rather than 12 frames. Its signaling bits are identified as "a", "b", "c" and "d".

**NOTE:** In an ESF frame, the a, b, c and d bits cannot be all zeroes (0000). Even though the ESF framing standard permits it, the AM8e Call Analyzer will not synchronize to an all zero ESF frame after conversion to EI.

You may change the framing type by pressing the FRAMING switch until the desired framing type is reached. The selected type is indicated by a lighted LED above the D3/D4 or ESF label.

## ZERO SUPPRESS switch and indicators — Handling Zero-data pattern

The zero suppression switch allows you to select the way that the T1 Adapter handles a data stream of all zeroes during transmission on the T1 side:

**S** Binary Eight Zero Suppression will insert two bipolar violations (BPVs) when seven consecutive zeroes are encountered. The receiving equipment will recognize this, remove the bipolar violation and correctly interpret the data.

Zero Code Suppression will insert a "1" bit to prevent the transmission of eight or more consecutive "0" bits.

Alternate Mark Inversion is the standard protocol for T1 Spans. AMI does not supply any zero suppression conversion.

## T1 and PCM2 indicators— Active Status of PCM Signals

Six LEDs indicate the current status of the T1 PCM signals. These LEDs are on either side of the labels for the various conditions indicated.

- SYNC:** This LED is lighted until the T1 has synchronized to the received data stream. When synchronization is achieved, the LED goes off.
- ERROR:** This LED is lighted when the T1 Adapter detects four errors in the frame bit pattern. If there is no error encountered for five seconds, the LED will turn off.  
This LED is lighted when the T1 adapter detects a slip condition. A slip is commonly due to buffer overflow or underflow of the network equipment. If there is no slip encountered for five seconds, the LED will turn off.
- BPV:** This LED is lighted when the T1 Adapter detects 256 or more bipolar violations. If there is no BPV for five seconds, the LED will turn off.
- RED ALM:** This LED is lighted when the T1 Adapter detects an "All-Ones-Signals" RED alarm condition or detects two frames of all-ones and an out-of-frame condition. The LED remains while the condition exists.
- YELLOW ALM:** This LED is lighted when the T1 Adapter detects a "Remote Alarm Indication" YELLOW alarm condition or detects a sequence of eight one's and eight zeroes in the Facility Data Link bit position. The LED remains lighted while the condition exists.

## **M1 and PCM2 HISTORY indicators — History Status of PCM Signals**

Outer LEDs are lighted when one of the active indicators is first lighted. Like the active indicators which go out automatically, the history status LEDs remain lighted until you press the HISTORY RESET switch.

### **HISTORY RESET switch. — Reset History Status**

Refer to 2.1.5, above.

## **MODE CONVersion T1 —> E1 switch and indicators Selecting Speech Encoding**

This switch (located between the FRAMING and HISTORY RESET switches) allows you to select the speech encoding conversion:

- > A A-law to A-law conversion passes speech samples through the unit in both directions without any conversion.
- > A  $\mu$ -law to A-law conversion converts  $\mu$ -law speech samples from the T1 circuit under test to the A-law tones required by the AM8e Call Analyzer. The AM8e Call Analyzer originates A-law speech samples which, are converted back to  $\mu$ -law by the T1 Adapter.

## Connection to the AM8e Call Analyzer

### AM8e LINE/TIMS — AM8e Interface Connection

is a DB-25 male connector, shown in Figure 1, where the 25-pin female connector of Cable 48015600 (supplied with the unit) is connected.

other end of this cable has a 24-pin ribbon connector which connects to the E/TIMS connector on the rear panel of the AM8e Call Analyzer. The signals by the T1 Adapter are as shown in Figure 2 (pin numbers at the AM8e Call Analyzer and the T1 Adapter connectors are also shown)

NAL	AM8e	Adapter	SIGNAL	AM8e	Adapter
12-R1	1	1	LID-R1	9	5
12-T1	2	14	LID-T1	10	18
12-R	3	2	LID-R	11	6
12-T	4	15	LID-T	12	19
11-R1	5	3	Gnd	21	11
11-T1	6	16	Gnd	22	24
11-R	7	4	+16 V Power	23	12
11-T	8	17	+16 V Power	24	25

**Table 2-1, Signal Connections**

- in: Power should be turned OFF on the AM8e before making this connection.
- in: When using the LINE/TIMS connector as a connection point from the AM8e Call Analyzer to the C.O. for PCM or LOOP signals (when not using the T1 Adapter), BE SURE THAT PINS 23 and 24 are NOT connected to C.O. ground.

These connections were not provided in early AM8e Call Analyzers, and Figure 7 - 18 in the Model AM8e PCM/VF Instruction Manual (March 1992 issue) shows pins 9 - 11 as unused, and pins 23 and 24 as extra C.O. GROUNDS. The latest October 1993 issue shows the connections for the T1 and other adapters.

## Connections to Test Leads

Connections for the PCM1 and PCM2 Rx and Tx interfaces may be made with one of the three types of cables which have a bantam connection on one end and a bantam plug, type 310 plug, or clip leads on the other end.

Figure 6-1 in the AM8e Call Analyzer manual (AM8e Instruction Manual, 18-5) shows the three types of cables. Figure 6-3 in the AM8e Call Analyzer manual shows the signals that appear on the tip, ring and sleeve of each jack which may be connected.

NOTE: Substitute the PCM1 and PCM2 jacks on the T1 Adapter for those shown in the AM8e Call Analyzer. Channels are limited to 1 - 24 rather than 1-30.

## Setting the Operating Conditions

The AM8e Call Analyzer and T1 Adapter must be configured correctly for T1 Signal characteristics. The basic steps for setting up, connecting and using the T1 Adapter follow:

Remove the Signaling Adapter from the front of the AM8e Call Analyzer by opening the holding clips on either side and set it on top of or beside the AM8e Call Analyzer.

After verifying that the AM8e Call Analyzer is turned OFF, connect the 48015600 Ribbon Cable (supplied) between the "TO AM8e LINES/TIMS" connector on the T1 Adapter and the LINE/TIMS connector on the AM8e Call Analyzer.

Turn ON the AM8e Call Analyzer and the T1 Adapter. LED indicators should indicate the settings for FRAMING and ZERO SUPPRESS. The FRAME SYNC indicator also will be lighted until the unit synchronizes to the incoming (Rx) T1 signal.

Set FRAMING and ZERO SUPPRESS on the T1 Adapter to match the characteristics of the T1 equipment under test (refer to 2.1.2 and 2.1.3).

**Note:** The ESF Framing standard allows all signalling bits to be zeroes; however, the AM8e Call Analyzer will not synchronize to an ESF Framed signal with all signaling bits equal to zero after conversion to EI.

Make the PCM1 and (if used) the PCM2 Rx and Tx connections between the labelled jacks on the T1 Adapter and the T1 equipment. For emulation by the AM8e Call Analyzer, disconnect through-connections (if not done by test jacks) at the CO. For monitoring, leave the connections in place.

**NOTES:**

- 1. When the AM8e Call Analyzer is to monitor the signal, it is expecting the Master clock via the signal connected to the PCM1 Rx jack on the T1 Adapter. The signal for the opposite direction must be connected to the PCM2 Rx jack on the T1 Adapter.
- 2. For further guidance to making Emulate or Repeat (Drop and Insert) connections refer to Figure A-6 in the AM8e Call Analyzer Instruction Manual, and substitute the PCM1 and PCM2 jacks on the T1 Adapter for those shown on the AM8e Call Analyzer. Internal channels are limited to 1 - 24 rather than 1-30.

Set the following AM8e Call Analyzer parameters:

<b>IMITATE</b>	"te/line" or "switch" (not significant for PCM operations)
<b>ANALOG/PCM</b>	<p>"pcm int clk" (Internal Clock) The AM8e Call Analyzer will generate the clock for PCM framing information. In this case, the AM8e Call Analyzer acts as a "Master" via the PCM1 or PCM2 Tx jack on the T1 Adapter.</p> <p>"pcm loop clk" (External Clock) The AM8e Call Analyzer uses the PCM signal it receives from the PCM1 Rx jack on the T1 Adapter.</p>
<b>PROTOCOL</b>	select the protocol appropriate for the T1 requirements at the test location.
<b>INPUT</b>	PCM1 and/or PCM2
<b>Channel</b>	1 - 24, as needed. Channels 25 - 30 are not accessible; they are used for communication between the T1 Adapter and the AM8e Call Analyzer.

To set up other parameters and perform tests, follow the procedures in the "Model AM8e PCM/VF Call Analyzer Instruction Manual" (18-0035).

• The T1 Protocol may automatically set the AM8e Call Analyzer parameters. If you have any further questions in setting up the test configuration, applications help is available from 8 AM to 5 PM Pacific Time by contacting Customer Service at the address or phone numbers on the title sheet of this manual.



## note Control of T1 Adapter

T1 Adapter may be configured directly through the use of the front panel MINING, ZERO SUPPRESS and HISTORY RESET and CODE CONVersion switches or remotely through a terminal connected to the AM8e Call Analyzer's 2 port. A command is used for setting each switch and another command is used to read the conditions that have been set up.

## note Setup ((ADP=xyz) command)

T1 Adapter switch can be set remotely through the use of the following command:

ADP=xyz)      x must be 2 for T1 Adapter  
                   y = switch  
                   z = switch selection as shown below:

	then z
framing	0 = d3/d4 1 = esf
zero suppress	0 = b8zs 1 = zcs 2 = ami
code conversion	0 = A → A 1 = μ → A
history reset	0 - 9 (don't care)

For example, the following commands would select ESF framing, AMI Zero suppression, conversion between μ-law and A-law encoding and reset the history registers.

(ADP=201)(ADP=212)(ADP=221)(ADP=230)

**Remote Status ((RADP) command):**

The settings of the T1 adapter switches (excluding the HISTORY RESET) and error message status can be read remotely through the use of the following command and response:

<u>command</u>	<u>response</u>
ADP)	ADAPTER STAT = fzc (as shown below)
	PCM1 CURRENT = nnnnnn
	PCM1 HISTORY = nnnnnn
	PCM2 CURRENT = nnnnnn
	PCM2 HISTORY = nnnnnn

<b>RAMING</b>	<b>z = ZERO SUPPRESS</b>	<b>c = CODE CONV</b>
D3/D4	0 = B8ZS	0 = A → A
ESF	1 = ZCS	1 = $\mu$ → A
	2 = AMI	

As an example, the setup status for D3/D4 framing type, AMI zero suppression,  $\mu$ -law to A-law conversion setup; and LED status showing non-synchronized channels, no current errors and un-reset history (all errors have occurred before the command was given) would be:

```
(RADP) ADAPTER STAT = 021
        PCM1 CURRENT = 100000
        PCM1 HISTORY = 111111
        PCM2 CURRENT = 100000
        PCM2 HISTORY = 111111
```

## **TECHNICAL SPECIFICATIONS**

### **Interface**

#### **PCM1 and/or PCM2)**

1.544 Mbps Pulse Code Modulation (PCM)

Modulation and Monitoring of User Protocol Definable circuit type (Protocol selected in AM8e)

Two span ports provided to support drop and insert channel (Repeat selections in AM8e)

Timing D3/D4, ESF

Zero Suppression: AMI, B8ZS, ZCS

Digital Channel Coding:  $\mu$ law, A-law

Impedance: 100  $\Omega$  at 1.544 Mbps BiPolar PCM (860  $\Omega$  padded cables applied for monitor mode)

## CM1 and PCM2 Transmission Error Indicators

- AME SYNC** This LED is lit until the until the T1 has synchronized to the recieved data stream. When synchronization is achieved, the LED goes off.
- AME ERROR** This LED is lit when the T1 Adapter detects four errors in the frame bit pattern. If there is no error encountered for five seconds, the LED will turn off.
- P** This LED is lit when the T1 adapter detects a slip condition. A slip is commonly due to buffer overflow or underflow of the network equipment. If there is no slip encountered for five seconds, the LED will turn off.
- V** This LED is lit when the T1 Adapter detects 256 or more bipolar violations. If there is no BPV for five seconds, the LED will turn off.
- (RED) ALM** This LED is lit when the T1 Adapter detects an "All-Ones-Signals" RED alarm condition or detects two frames of all-ones and an out-of-frame condition. The LED remains while the condition exists.
- (YEL) ALM** The LED is lit when the T1 Apadter detects a "Remote Alarm Indication" Yellow alarm condition or detects a sequence of eight one's and eight zeroes in the Facility Data Link bit position. The LED remains lit while the condition exists.